



# Interconnection Request Technical Data Submittal Guidance

© ISO New England Inc.

REVISION: 1.0  
DATE: 07/21/2025



This page is intentionally left blank.

## Disclaimer

In case of any discrepancy with this guidance document, Schedule 22 – Large Generator Interconnection Procedures, Schedule 23 – Small Generator Interconnection Procedures, and Schedule 25 – ETU Interconnection Procedures of the ISO’s Open Access Transmission Tariff and applicable Planning and Operating Procedures govern<sup>1</sup>.

---

<sup>1</sup> <https://www.iso-ne.com/participate/rules-procedures/tariff/oatt>  
<https://www.iso-ne.com/participate/rules-procedures/operating-procedures>  
<https://www.iso-ne.com/participate/rules-procedures/planning-procedures>

# Contents

|  |            |
|--|------------|
| <b>Disclaimer</b> .....  | <b>iii</b> |
| <b>Contents</b> .....  | <b>iv</b>  |
| <b>Figures</b> .....   | <b>vi</b>  |
| <b>Tables</b> .....  | <b>vii</b> |
| <b>Section 1 Introduction</b> .....  | <b>8</b>   |
| 1.1 Required Submittals .....  | 8          |
| 1.1.1 Additional guidance on Site Map submittal .....  | 10         |
| 1.1.2 IR Data Input and File Upload.....   | 10         |
| 1.1.3 Model Data Software Compatibility .....  | 11         |
| <b>Section 2 Data Deficiencies and Recommended Resolutions</b> .....                               | <b>12</b>  |
| 2.1 Interconnection Request Form Technical Data .....  | 12         |
| 2.1.1 Electric Storage Device Data Requirements .....  | 12         |
| 2.1.2 Generating Facility Capacity Data Requirements .....   | 12         |
| 2.1.3 Impact on Study Models .....   | 14         |
| 2.2 Attachment A Technical Data .....  | 14         |
| 2.2.1 Reactive Capability (PQ) Curve Data Requirements .....                                       | 15         |
| 2.2.2 Impact on Study Models .....   | 15         |
| 2.3 Attachment A-1 – Supplementary Wind and Inverter-Based Generating Facility Technical Data..... | 16         |
| 2.3.1 Item 2 of Attachment A-1 .....   | 16         |
| 2.3.2 Item 3 of Attachment A-1 .....   | 16         |
| 2.3.3 Item 4 of Attachment A-1 .....   | 17         |
| 2.3.4 Item 6 of Attachment A-1 .....   | 19         |
| 2.3.5 Item 7 and Item 8 of Attachment A-1 .....  | 20         |
| 2.3.6 Item 9 and Item 10 of Attachment A-1 .....   | 22         |
| 2.3.7 Item 14 of Attachment A-1 .....  | 23         |
| <b>Section 3 Generating Plant Component Modeling Guidelines</b> .....                              | <b>25</b>  |
| 3.1.1 PSSE Dynamic Models .....  | 25         |
| 3.1.2 PSSE Dynamic Model Initialization Error .....  | 25         |
| 3.1.3 PSSE Power Plant Controller (PPC) Dynamic Model .....  | 25         |
| 3.1.4 Frequency Droop in PSSE and PSCAD Model .....  | 26         |
| 3.1.5 ASPEN OneLiner IBR Modeling .....  | 26         |
| 3.1.6 PSCAD Model Components .....   | 27         |
| <b>Section 4 Modeling Data Alignment</b> .....   | <b>28</b>  |

4.1 Data Alignment in Simulation Tools .....28  
4.1.1 Steady State Data Alignment Guidelines .....28  
4.1.2 Dynamic Data Alignment Guidelines.....29

# Figures

|  |    |
|--|----|
| Figure 1 Interconnection Request Form and Attachments..... | 11 |
| Figure 2 IRTT Attachment Upload .....                      | 11 |
| Figure 3 Electric Storage Device Data .....                | 12 |
| Figure 4 Generating Facility Capacity .....                | 13 |
| Figure 5 Generating Facility Limited Output.....           | 14 |
| Figure 6 Reactive Capability (PQ) Curve .....              | 15 |
| Figure 7 Item 3 of Attachment A-1 .....                    | 17 |
| Figure 8 Item 4 of Attachment A-1 .....                    | 18 |
| Figure 9 Item 6 of Attachment A-1 .....                    | 20 |
| Figure 10 Item 7 and Item 8 of Attachment A-1 .....        | 21 |
| Figure 11 Item 9 and Item 10 of Attachment A-1 .....       | 22 |
| Figure 12 Item 14 of Attachment A-1 .....                  | 23 |
| Figure 13 IBR Single Aggregate Representation .....        | 26 |
| Figure 14 IBR Multiple Aggregate Representation .....      | 26 |
| Figure 15 Converter-Interfaced Resources .....             | 27 |

## Tables

|  |    |
|--|----|
| Table 1 Steady State Data Alignment Guidelines ..... | 28 |
| Table 2 Dynamic Data Alignment Guidelines .....      | 29 |

# Section 1

## Introduction

The Interconnection Request Tracking Tool (IRTT)<sup>2,3</sup> is used by Interconnection Customers (IC) for submittals and by ISO New England (ISO) for review and approval of Interconnection Requests (IR) for Generating Facilities and Elective Transmission Upgrades (ETUs). This guide provides detailed guidance on the technical data that must be provided to support an IR. In addition, it also highlights frequently identified deficiencies in the technical data submitted to ISO and provides guidance on how to address these deficiencies.

Please note that while the ISO attempts to keep this guide current, all screen shots used in this guide may not fully reflect the current IRTT production environment.

### 1.1 Required Submittals

---

Pursuant to Section 3.4.2 of Schedules 22 and 23 and Section 3.3.2 of Schedule 25, ICs must submit technical data (i.e., completed form Appendix 1 and all information required under its attachments) for the IR to be considered as valid. To do so, ICs must submit the following:

#### General Items

- A completed IR form
- A valid Site Map document for the Generating Facility or HVDC terminal(s) associated with the ETU in PDF and KMZ format
- Valid Site Control<sup>4</sup> for the Generating Facility or HVDC terminal(s) associated with the ETU preferably in PDF format
- A completed signature page preferably in PDF format

#### Attachments to IR

- A completed Attachment A form
- A completed Attachment A-1 To Attachment A of Appendix 1 Supplementary Wind and Inverter-Based Generating Facility Form, if applicable
- Completed Planning Procedure 5-6<sup>5</sup>, Appendix C-1<sup>6</sup>, C-1A and C-1B forms, if submitting new or revised Electromagnetic Transient (EMT) (i.e. PSCAD) models
  - *Completed Appendix C-1 checklist and e-MQA forms are required* for the inverter, HVDC, Power Plant Controller (PPC) and any dynamic reactive device such as SVC, STATCOM, DVAR etc.

---

<sup>2</sup> <https://irtt.iso-ne.com/account/login>

<sup>3</sup> [https://www.iso-ne.com/static-assets/documents/support/user\\_guides/irtt\\_user\\_guide.pdf](https://www.iso-ne.com/static-assets/documents/support/user_guides/irtt_user_guide.pdf)

<sup>4</sup> [https://www.iso-ne.com/static-assets/documents/100024/notice\\_re\\_regulatory\\_limitations\\_and\\_site\\_control\\_6\\_2\\_25.pdf](https://www.iso-ne.com/static-assets/documents/100024/notice_re_regulatory_limitations_and_site_control_6_2_25.pdf)

<sup>5</sup> [https://www.iso-ne.com/static-assets/documents/rules\\_proceeds/isone\\_plan/pp05\\_6/pp5\\_6.pdf](https://www.iso-ne.com/static-assets/documents/rules_proceeds/isone_plan/pp05_6/pp5_6.pdf)

<sup>6</sup> [https://www.iso-ne.com/static-assets/documents/100010/pp5\\_6\\_appendix\\_c1.pdf](https://www.iso-ne.com/static-assets/documents/100010/pp5_6_appendix_c1.pdf)



## Generator Technical Data

- Reactive power (PQ) capability curve
- Load flow model in PSSE “RAW” format
- Dynamic model in PSSE “DYN” format
- Short circuit model in ASPEN OneLiner “OLR” format
- EMT model in PSCAD “PSCX” format and all required auxiliary files (obj, lib, DLL, txt etc.) in a single ZIP file
- A geographic map demonstrating the Project layout and its proposed interconnection to the power grid in both PDF and KMZ format
- A bus-breaker based one-line diagram in PDF format
- A collection system detail impedance sheet in Microsoft Excel format
- A collection system aggregate model data sheet in Microsoft Excel format
- Collection System/Transformer Tap-Setting Design in PDF format

## Generator Model Supporting Documents, if submitting new or revised EMT or PSSE model

- A PSSE-PSCAD benchmark report in Microsoft Word format
- PSCAD model user documentation in PDF format
- Inverter-based generating facility technical manual from the manufacturer including description of LVRT functionality in PDF format

### 1.1.1 Additional guidance on Site Map submittal

The site map, to be submitted in both PDF and KMZ format, should include

- Tag with project location, GPS coordinates and address (if available)
- Boundary of the project location
- Point Of Interconnection (POI) name and voltage level
- Gen-tie from project location to POI
- Length of gen-tie

### 1.1.2 IR Data Input and File Upload

The data required to support a valid IR is provided using IRTT in two ways:

- Forms that must be completed in IRTT
- Supporting documents that must be uploaded into IRTT

#### 1.1.2.1 Forms to be completed in IRTT

The following forms must be completed in IRTT

- Project Information
- Attachment A
- Attachment A-1
- Signature Page



**Figure 1 Interconnection Request Form and Attachments**

*1.1.2.2 Supporting documents to be uploaded to IRTT*

All supporting documents to be uploaded to IRTT must be done so using the “Uploads” tab as shown below.

Each document uploaded must be associated with the corresponding document type. For example, the reactive power (PQ) capability curve should be uploaded under the document type as shown in Figure 2.

For instances where a document does not have a corresponding document type, the document should be uploaded under the “General Project Documents” document type. The document’s file name should clearly indicate the content of the document.

**Figure 2 IRTT Attachment Upload**

**1.1.3 Model Data Software Compatibility**

The modeling data submitted must be compatible with the in-effect software version designated by ISO. The in-effect software version is available on the following website:

<https://www.iso-ne.com/participate/applications-status-changes/interconnection-process-guide>

## Section 2

# Data Deficiencies and Recommended Resolutions

This section highlights common technical data issues found in interconnection submissions and provides guidance to aid ICs on how to avoid these frequent deficiencies. This section does not represent every possible issue that may arise during the review process.

### 2.1 Interconnection Request Form Technical Data

Common technical data deficiencies seen in submitted IR forms and recommendations for avoiding them are discussed below.

#### 2.1.1 Electric Storage Device Data Requirements

Electric storage device data commonly lacks sufficient technical specifications in their IR. At a minimum, the specifications should include the following:

|  |  |
|--|--|
| <p>Will the Generating Facility include electric storage capacity?</p> <p><input checked="" type="radio"/> Yes</p> <p>If yes, describe the electric storage device and specifications</p> <p>A</p> | <p>A. Storage Device Specification Data</p> <ul style="list-style-type: none"> <li>• Total Storage Capability (MWh AC) at generator terminal</li> <li>• Net Storage Discharging Power at POI (MW)</li> <li>• Gross Storage Charging Power (MW) at POI</li> </ul> |
|--|--|

Figure 3 Electric Storage Device Data

##### 2.1.1.1 Additional guidance on data input

Additional guidance on storage device specification data is provided below

- Net Storage Discharging Power (MW) – The discharge power at which the project is proposing to operate such that it achieves requested net injection at the POI.
  - This value must align with the “Net MW Capability at the POI” value provided in the Generating Facility Capacity table as shown in Figure 4.
  - For generating facility with limiting output, this value must align with the “Requested Net MW Capability at the POI” value provided in the Generating Facility Capacity table as shown in Figure 5.
- Gross Storage Charging Power (MW) – The charging power at which the project is proposing to operate such that it achieves intended gross absorption at the POI. This value may be different from the storage device discharging power.

#### 2.1.2 Generating Facility Capacity Data Requirements

Generating facility capacity data frequently contains inaccurate values in the required data table. The generating facility capacity table requires three sets of data as shown in Figure 4. The

requested net MW value in the item labeled C will be evaluated in the study and cannot be increased.<sup>7</sup>

| Generating Facility Capacity (MW) |   |   |  |
|-----------------------------------|---|---|--|
| Temperatures <sup>1</sup>         | Maximum Gross MW Electrical Output <sup>2</sup> | Maximum Net MW Electrical Output <sup>3</sup> | Net MW Capability at the Point of Interconnection <sup>4</sup> |
| At or above 90 degrees F *        | Gross @ 90                                      | Net @ 90                                      | Net MW Capability @ 90   |
| At or above 50 degrees F *        | Gross @ 50 <b>A</b>                             | Net @ 50 <b>B</b>                             | Net MW Capability @ 50 <b>C</b>                                |
| At or above 20 degrees F *        | Gross @ 20                                      | Net @ 20                                      | Net MW Capability @ 20   |
| At or above 0 degrees F *         | Gross @ 0                                       | Net @ 0                                       | Net MW Capability @ 0  |

A. This is the gross output of the generator at the inverter/converter terminals

B. This is the generator output less any station service load at the inverter/converter terminal. If there is no station service load modeled at the inverter/converter terminal, A and B can be the same value.

C. This is the generator output at the POI less any station service load and losses within the interconnection facility.

*An example is provided below for illustrative purposes:*

A solar plant with a proposed net injection of 85 MW has the following characteristics

Gross output (X): 100 MW

Station Service load (Y) : 5 MW at the generator terminal

Losses (Z): 10 MW within the interconnection facility

The Generator Facility Capacity table will be completed in the following manner for this generating facility (assumes gross output is independent of ambient temperature):

Item A = X = 100 MW

Item B = X – Y = 95 MW

Item C = X-Y-Z = 85 MW

For most generating facilities,  $A \geq B > C$

**Figure 4 Generating Facility Capacity**

**2.1.2.1 Generating Facility with Limiting Output**

Where the requested capacity of Interconnection Service is lower than the Generating Facility Capacity, an additional data table must be completed. Some possible configurations where this may be applicable include:

- A hybrid or a co-located plant such PV+BESS

<sup>7</sup> Refer to Section 4.4.1 of Schedule 22, 23 and 25 for requirements to changes in Generating Facility output

- A plant with more generating capacity installed than required to achieve the desired net injection at the POI

An example to illustrate one such configuration is shown below. This configuration assumes a 200 MW hybrid generating facility (100 MW PV and 100 MW BESS) with a proposed net injection of 150 MW and has the following characteristics

Gross output = 200 MW at the generator terminal  
 Station service load = 10 MW at the generator terminal  
 Losses = 10 MW within the interconnection facility

Following the same calculation steps shown in Figure 4, the generating facility capacity table is completed as shown below in Figure 5. The requested net MW value in the item labeled F will be evaluated in the study and cannot be increased.<sup>7</sup>

| Generating Facility Capacity (MW) |   |   |  |
|-----------------------------------|---|---|--|
| Temperatures <sup>1</sup>         | Maximum Gross MW Electrical Output <sup>2</sup> | Maximum Net MW Electrical Output <sup>3</sup> | Net MW Capability at the Point of Interconnection <sup>4</sup> |
| At or above 90 degrees F *        | 200   | 190   | 180  |
| At or above 50 degrees F *        | 200 <b>A</b>                                    | 190 <b>B</b>                                  | 180 <b>C</b>   |
| At or above 20 degrees F *        | 200   | 190   | 180  |
| At or above 0 degrees F *         | 200   | 190   | 180  |

Requested capacity (in MW) of Interconnection Service (if lower than the Generating Facility Capacity)

| Temperatures <sup>1</sup> | Requested Gross MW Electrical Output <sup>2</sup> | Requested Net MW Electrical Output <sup>3</sup> | Requested Net MW Capability at the Point of Interconnection <sup>4</sup> |
|---------------------------|---|---|--|
| At or above 90 degrees F  | 170   | 160   | 150  |
| At or above 50 degrees F  | 170 <b>D</b>                                      | 160 <b>E</b>                                    | 150 <b>F</b>   |
| At or above 20 degrees F  | 170   | 160   | 150  |
| At or above 0 degrees F   | 170   | 160   | 150  |

**Figure 5 Generating Facility Limited Output**

### 2.1.3 Impact on Study Models

The following study models are impacted by this data:

- PSSE
- PSCAD

The net injection in the PSSE and PSCAD model should align with the values provided in item C of Figure 4 or item F of Figure 5, as applicable.

## 2.2 Attachment A Technical Data

The frequently identified technical data deficiencies in Attachment A to the Interconnection Request form and recommended resolutions are discussed below.

### 2.2.1 Reactive Capability (PQ) Curve Data Requirements

Attachment A requires a generator reactive capability (PQ) curve to be uploaded as shown below. A common deficiency is the omission of the generator's full capability as intended for the proposed project.

**Attachment A**

**Curves**  
Provide Saturation, Vee, Reactive Capability, Capacity Temperature Correction curves. Designate normal and emergency Hydrogen Pressure operating range for multiple curves.

Use the **Uploads** tab to upload the Curves

**Comments**

An example to illustrate the expected data is shown below. This example assumes a project proposing to use an inverter operating at 3 MW output at its terminal. The green line in PQ curve in Figure 6 shows the generator's full capability as intended for the proposed project.

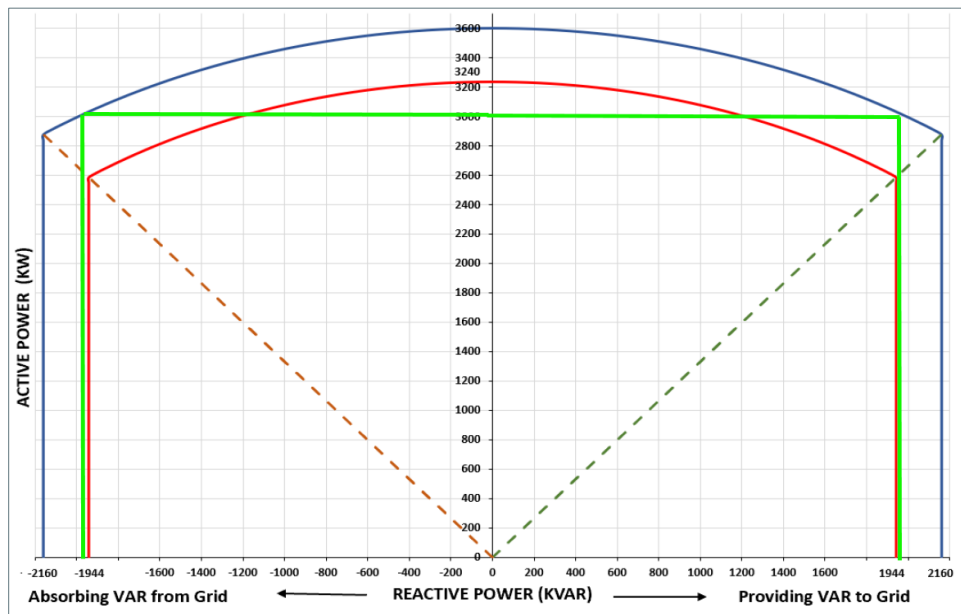

**Figure 6 Reactive Capability (PQ) Curve**

### 2.2.2 Impact on Study Models

The following study models are impacted by this data:

- PSSE
- PSCAD

The active and reactive power modeled for the inverter in PSSE and PSCAD should align with its full capability as intended for the proposed project.

## 2.3 Attachment A-1 – Supplementary Wind and Inverter-Based Generating Facility Technical Data

---

The frequently identified technical data deficiencies in Attachment A-1 to the Interconnection Request form and recommended resolutions are discussed below.

### 2.3.1 Item 2 of Attachment A-1

Common deficiencies with single-line diagram (SLD) involve insufficient project details and inconsistencies with data provided in other sections of the IR and related attachments.

The SLD should

- show applicable equipment such as generating units, step-up transformers and auxiliary transformers
- show transformer winding connections
- include the collector system
- include required switches/disconnects and circuit breakers
- show the main power transformer, if applicable
- show the distance from one end of the line terminals to a line tap if tapping a line<sup>8</sup>
- show the breaker position if connecting to an existing substation
- align with parameters provided in other sections of the IR and related attachments
  - such parameters include transformer impedances, winding connections etc.

#### 2.3.1.1 Impact on study models

The following study models are impacted by this data:

- PSSE
- PSCAD
- ASPEN

To ensure modeling accuracy, the applicable data provided in item 2 of Attachment A-1 should align with the respective study models.

### 2.3.2 Item 3 of Attachment A-1

The screenshot below illustrates the specific data requirements for item 3 of Attachment-1. This section provides detailed guidance on completing these requirements.

A common deficiency involves inaccurately specifying the generator's capability as intended for the proposed project.

---

<sup>8</sup> Refer to [PP5-6](#), Appendix A and [PP09](#) for station configuration requirements

| 3. Summary of the Unit Models in the wind or inverter-based generating facility |  |
|---|--|
| Unit Name *   | A  |
| Manufacturer Model  | B  |
| Type of this WTG* (If applicable)<br>- Select -                                 | Generator Unit Numbers in the field<br>D |
| Number(s) of these Units<br>E   | Maximum Output of this Unit (Mw)<br>F    |
| Total MW<br>G   |  |

**Figure 7 Item 3 of Attachment A-1**

- A – Provide name of inverter manufacturer
- B – Provide inverter model number
- C – Provide WTG Type (if applicable)
- D – Provide the total number of inverters as a range. For example, if there are 50 inverters, input 1-50
- E – Provide the total number of inverters
- F- Rated output of individual inverter as proposed for the project
- G – Total rated output of all inverters

#### 2.3.2.1 Impact on Study Models

The following study models are impacted by this data:

- PSSE
- PSCAD

The gross output at the inverter terminals in the PSSE and PSCAD model should align with the values provided in item A of Figure 4, item D of Figure 5 and item G as shown in Figure 7.

#### 2.3.3 Item 4 of Attachment A-1

The screenshot below illustrates the specific data requirements for item 4 of Attachment-1. This section provides detailed guidance on completing these requirements.

A common deficiency involves submitting data for the aggregate generating facility rather than a single inverter.

| 4. Unit Detail Information   |  |
|--|--|
| Unit Manufacturer Model<br><input type="text" value="A"/>  | Terminal Voltage<br><input type="text" value="B"/>   |
| Rating of Each Unit (MVA)<br><input type="text" value="C"/>                                      |  |
| Maximum Gross Electrical Output (MW)<br><input type="text" value="D"/>                           | Minimum Gross Electrical Output (MW)<br><input type="text" value="E"/>                           |
| Lagging Reactive Power Limit at Rated Real Power Output (MVAR)<br><input type="text" value="F"/> | Leading Reactive Power Limit at Rated Real Power Output (MVAR)<br><input type="text" value="G"/> |
| Lagging Reactive Power Limit at Zero Real Power Output (MVAR)<br><input type="text" value="H"/>  | Leading Reactive Power Limit at Zero Real Power Output (MVAR)<br><input type="text" value="I"/>  |
| Station Service Load(MW, MVAR)<br><input type="text" value="J"/>                                 | Minimum short circuit ratio(SCR) requirement by manufacturer<br><input type="text" value="K"/>   |
| On which bus the minimum SCR is required by manufacturer<br><input type="text" value="L"/>       | What voltage level the minimum SCR is required by manufacturer<br><input type="text" value="M"/> |
| Positive sequence Xsource<br><input type="text" value="N"/>                                      | Zero sequence Xsource<br><input type="text" value="O"/>  |

**Figure 8 Item 4 of Attachment A-1**

- A – Provide inverter manufacturer and model number
- B – Provide inverter terminal voltage in kV
- C - Provide MVA rating of a single inverter
- D – Provide the maximum gross output of a single inverter as intended for the project
  - The product of this value and the number of inverters (that is, the total gross output at the inverter terminal) must align with the values provided in item G of Figure 7. It must also align with item A of Figure 4 or item D of Figure 5, as applicable.
  - This value must also align with the PQ curve as discussed in section 2.2.1
- E – Provide the minimum gross output of a single inverter as intended for the project
  - This value is typically zero for most resources except for energy storage devices where the value is negative
  - For energy storage devices, the product of this value and the number of inverters (that is, the total net absorption at the inverter terminal) plus the losses in the Interconnection Customer’s Interconnection Facilities should equal to the Gross Storage Charging Power (MW) at the POI as discussed in section 2.1.1 when modeled in PSSE and PSCAD
- F – Provide the lagging reactive power limit at the rated real power output of a single inverter
  - The rated real power output is the value provided in item D of Figure 8
  - This value must also align with the PQ curve as discussed in section 2.2.1
- G - Provide the leading reactive power limit at the rated real power output of a single inverter
  - The rated real power output is the value provided in item D of Figure 8
  - This value must also align with the PQ curve as discussed in section 2.2.1
- H - Provide the lagging reactive power limit at zero real power output of a single inverter, if applicable
- I - Provide the leading reactive power limit at zero real power output of a single inverter, if applicable

- J – Provide the total station service load for the generating facility
- K – Provide the minimum SCR required by the manufacturer
- L – Provide the location within the interconnection customer’s interconnection facility where the minimum SCR is required. This is typically at the inverter terminal bus.
- M – Provide the voltage level of the bus where the minimum SCR is required. This is typically at the inverter terminal bus voltage.
- N – Provide the positive sequence reactance (Xsorce) of a single inverter
  - If the PSSE library model REGC\_A is used for the inverter’s dynamic model, then a value of 9999 is typically used
  - If the PSSE library model REGC\_B is used for the inverter’s dynamic model,
    - Xsorce is intended to emulate the effective source impedance of the VSC full-converter and generally represents the smoothing reactor/filter of the VSC
    - This value is used as the “xe” value in the REGC\_B model<sup>9</sup>
    - This value must be obtained from the inverter manufacturer
- O - Provide the zero sequence reactance (Xsorce) of a single inverter. This value is typically 9999.

#### 2.3.3.1 Impact on study models

The following study models are impacted by this data:

- PSSE
- PSCAD
- ASPEN

To ensure modeling accuracy, the data provided in item 4 of Attachment A-1 must be consistent across all applicable study models.

#### 2.3.4 Item 6 of Attachment A-1

The screenshot below illustrates the specific data requirements for item 6 of Attachment-1. This section provides detailed guidance on completing these requirements.

---

<sup>9</sup> Refer to PSSE Version 35 Model Library Documentation

6. Low Voltage Ride Through (LVRT) (Specify the Manufacturer Model of this Unit)

A

Does each Unit have LVRT capability?

Yes

If yes, please provide:

B

**6.1 Unit LVRT mode activation and release condition**

When operating at maximum real power, what is the Unit terminal voltage for LVRT mode activation?

C

When operating at maximum real power, what is the Unit terminal voltage for releasing LVRT mode after it is activated?

D

If there is different LVRT activation and release logic, please state here

E

**6.2 A Wind or other inverter-based generating facility technical manual from the manufacturer including description of LVRT functionality**

F

Attach an Inverter-Based Generating Facility Technical Manual from the manufacturer. Attachments can be added on the upload tab.

**Figure 9 Item 6 of Attachment A-1**

- A – Provide the inverter manufacturer
- B – State whether the inverter has low voltage ride-through (LVRT) capability
- C – Provide the terminal voltage at which LVRT is activated
  - This value must align with the respective PSSE and PSCAD models provided for the generating facility
- D - Provide the terminal voltage at which LVRT is deactivated
  - This value must align with the respective PSSE and PSCAD models provided for the generating facility
- E – Provide LVRT activation and deactivation logic if different from item C and D
- F – Provide inverter technical manual with details on LVRT logic

#### 2.3.4.1 Impact on study models

The following study models are impacted by this data:

- PSSE
- PSCAD

To ensure modeling accuracy, the data provided in item 6 of Attachment A-1 must be consistent across all applicable study models.

#### 2.3.5 Item 7 and Item 8 of Attachment A-1

The screenshot below illustrates the specific data requirements for item 7 and item 8 of Attachment-1. This section provides detailed guidance on completing these requirements.

Common deficiencies involve submitting data that does not comply with NERC Standard PRC-024-3<sup>10</sup> requirements and inconsistencies between study models.

|   |                                    |
|---|------------------------------------|
| <b>7. Low Voltage Protection (considering LVRT functionality) *</b>               |                                    |
| (Specify the Manufacturer Model of this Unit)                                     |                                    |
| A   |                                    |
| *Add more rows in the table as needed   |                                    |
| <b>Low Voltage Setting (pu)</b>   | <b>Relay Pickup Time (Seconds)</b> |
|   |                                    |
|   |                                    |
| <b>8. High Voltage Protection - (Specify the Manufacturer Model of this Unit)</b> |                                    |
| (Specify the Manufacturer Model of this Unit)                                     |                                    |
| B   |                                    |
| *Add more rows in the table as needed   |                                    |
| <b>High Voltage Setting (pu)</b>  | <b>Relay Pickup Time (Seconds)</b> |
|   |                                    |
|   |                                    |

**Figure 10 Item 7 and Item 8 of Attachment A-1**

- A – Provide low voltage ride-through protection settings
  - The ride-through protection settings must comply with NERC Standard PRC-024-3
  - The ride-through protection settings should utilize the inverter’s full operational capability to the maximum extent possible
  - The ride-through protection settings should consider a reasonable breaker operating time unless explicitly modeled
- B – Provide high voltage ride-through protection settings
  - The ride-through protection settings must comply with NERC Standard PRC-024-3
  - The ride-through protection settings should utilize the inverter’s full operational capability to the maximum extent possible
  - The ride-through protection settings should consider a reasonable breaker operating time unless explicitly modeled

#### 2.3.5.1 Impact on study models

The following study models are impacted by this data:

- PSSE
- PSCAD

To ensure modeling accuracy, the data provided in item 7 and item 8 of Attachment A-1 must be consistent across all applicable study models.

---

<sup>10</sup> Per PP5-6, generating facilities must comply with NERC Standard PRC-024-3, which remains enforceable pending FERC approval of replacement standard PRC-029-01

### 2.3.6 Item 9 and Item 10 of Attachment A-1

The screenshot below illustrates the specific data requirements for item 9 and item 10 of Attachment-1. This section provides detailed guidance on completing these requirements.

Common deficiencies involve submitting data that does not comply with NERC Standards PRC-024-3 and PRC-006-NPCC-2 requirements and inconsistencies between study models.

| 9. Low Frequency Protection - Specify the Manufacturer Model of this Unit     |                             |
|---|-----------------------------|
| A   |                             |
| *Add more rows in the table as needed   |                             |
| Low Frequency Setting (Hz)  | Relay Pickup Time (Seconds) |
|   |                             |
|   |                             |
| 10. High Frequency Protection - (Specify the Manufacturer Model of this Unit) |                             |
| B   |                             |
| *Add more rows in the table as needed   |                             |
| High Frequency Setting (Hz)   | Relay Pickup Time (Seconds) |
|   |                             |
|   |                             |

**Figure 11 Item 9 and Item 10 of Attachment A-1**

- A – Provide low frequency ride-through protection settings
  - The ride-through protection settings must comply with NERC Standards PRC-024-3 and PRC-006-NPCC-2
  - The ride-through protection settings should utilize the inverter’s full operational capability to the maximum extent possible
  - The ride-through protection settings should consider a reasonable breaker operating time unless explicitly modeled
- B – Provide high frequency ride-through protection settings
  - The ride-through protection settings must comply with NERC Standard PRC-024-3
  - The ride-through protection settings should utilize the inverter’s full operational capability to the maximum extent possible
  - The ride-through protection settings should consider a reasonable breaker operating time unless explicitly modeled

#### 2.3.6.1 Impact on study models

The following study models are impacted by this data:

- PSSE
- PSCAD

To ensure modeling accuracy, the data provided in item 9 and item 10 of Attachment A-1 must be consistent across all applicable study models.

### 2.3.7 Item 14 of Attachment A-1

The screenshot below illustrates the specific data requirements for item 14 of Attachment-1. This section provides detailed guidance on completing these requirements.

A common deficiency involves insufficient details and inconsistencies with data provided in other sections of the IR and related attachments.

| 14. Station Transformer   |                      |   |                      |
|---|----------------------|---|----------------------|
| Transformer Name  |                      | Nameplate ratings (MVA)                                       |                      |
| <input type="text"/>  |                      | <input type="text"/>  |                      |
| Total number of the main transformer(s)                           |                      | Voltage, High/Low/Tertiary (kV)                               |                      |
| <input type="text"/>  |                      | <input type="text"/>  |                      |
| Winding connections, High/Low Tertiary                            |                      | Available tap positions on high voltage side                  |                      |
| <input type="text"/>  |                      | <input type="text"/>  |                      |
| Available tap positions on low voltage side                       |                      | Will the transformer operate as a LTC?                        |                      |
| <input type="text"/>  |                      | <input type="radio"/> No <input checked="" type="radio"/> Yes |                      |
| Desired voltage control range if LTC                              |                      |   |                      |
| <input type="text"/>  |                      |   |                      |
| Tap adjustment time (Tap switching delay + switching time) if LTC |                      |   |                      |
| <input type="text"/>  |                      |   |                      |
| Desired tap position if applicable                                |                      | Tap adjustment time (Tap switching delay + switching time)    |                      |
| <input type="text"/>  |                      | <input type="text"/>  |                      |
| Impedance $Z_1$ , X/R ratio                                       |                      | Impedance $Z_0$ , X/R ratio                                   |                      |
| $Z_{1H-L}$  | X/R                  | $Z_{0H-L}$  | X/R                  |
| <input type="text"/>  | <input type="text"/> | <input type="text"/>  | <input type="text"/> |
| $Z_{1H-T}$  | X/R                  | $Z_{0H-T}$  | X/R                  |
| <input type="text"/>  | <input type="text"/> | <input type="text"/>  | <input type="text"/> |
| $Z_{1T-L}$  | X/R                  | $Z_{0T-L}$  | X/R                  |
| <input type="text"/>  | <input type="text"/> | <input type="text"/>  | <input type="text"/> |

Figure 12 Item 14 of Attachment A-1

- A – Provide a transformer name, for example, MPT
- B – Provide all applicable MVA ratings
  - This should include ONAN/ONAF/OFAP ratings
  - The ratings should allow the generating facility to operate at full active and reactive power without causing a thermal overload
- C – Provide total number of main transformers
- D – Provide high, low and tertiary voltage
- E – Provide high, low and tertiary winding connections
- F – Provide available tap positions on the high-side
- G – Provide available tap positions on the low-side
- H – Indicate whether transformer will operate as a load tap changer (LTC)
- I – Provide voltage regulation range if operating as a LTC and the bus it will regulate
  - The medium voltage (MV) bus is typically the regulated bus
  - The voltage regulation range should allow the generating facility to maximize its reactive power capability while maintaining acceptable voltage levels on the regulated bus
- J – Provide a reasonable tap adjustment time if operating as an LTC
  - If adjustment time is less than or equal to 10 seconds, a dynamic model is strongly recommended for the transformer

- K – Provide desired tap position
  - This should align with the Collection System/Transformer Tap-Setting Design document provided in item 18 of Attachment A-1
- L – Provide positive sequence impedance, X/R ratio and MVA base for impedance calculation
- M – Provide zero sequence impedance, X/R ratio and MVA base for impedance calculation

#### *2.3.7.1 Impact on study models*

The following study models are impacted by this data:

- PSSE
- PSCAD
- ASPEN

To ensure modeling accuracy, the data provided in item 14 of Attachment A-1 must be consistent across all applicable study models.

## Section 3

# Generating Plant Component Modeling Guidelines

This section provides modeling guidance for key generating plant<sup>11</sup> components that commonly require clarification during technical reviews.

### 3.1.1 PSSE Dynamic Models

As stated in Appendix B of Planning Procedure 5-6 (PP5-6), the most up-to-date revision of the library models available in the PSSE version in effect as identified by ISO-NE for appropriately representing the project equipment should be used<sup>12</sup>.

### 3.1.2 PSSE Dynamic Model Initialization Error

The PSSE dynamic model should be parametrized such that it does not show initialization errors at the following operating points at the generator terminal

- Pmax and Qmax
- Pmax and Qmin
- Pmin and Qmax
- Pmin and Qmin

### 3.1.3 PSSE Power Plant Controller (PPC) Dynamic Model

Inverter-based resources (IBR) are typically represented in power flow either as a single aggregate or as multiple aggregates as shown in Figure 13 and Figure 14, respectively. The most up-to-date available dynamic model that aligns with the chosen aggregation method should be used for the PPC<sup>13</sup>.

---

<sup>11</sup> The term “generating plant” is used to represent the Generating Facility and the Interconnection Customer’s Interconnection Facilities both of which are defined in Section 1 of Schedule 22, 23 and 25 of the OATT

<sup>12</sup> Models used should be numerically robust and capable of capturing inverter dynamics. For generic renewable energy models, these would include the REGC\_B (generator model), REEC\_D (electrical model) and REPC\_C (Power Plant Controller model). REPC\_A model for the PPC is also acceptable, however, REPC\_C is strongly recommended.

<sup>13</sup> For generic renewable energy models, these would include the REPC\_C model for single aggregate representation and PLNTBU1 for multiple aggregate representation

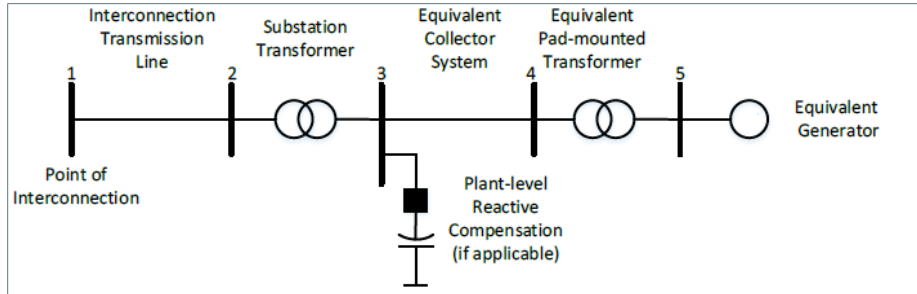

**Figure 13 IBR Single Aggregate Representation**

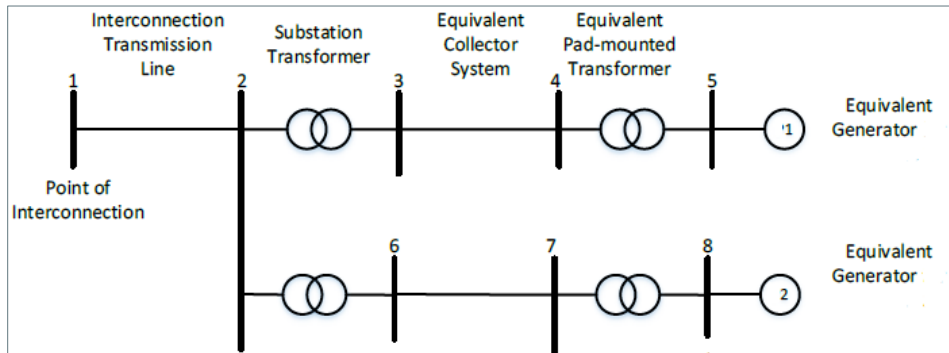

**Figure 14 IBR Multiple Aggregate Representation**

### 3.1.4 Frequency Droop in PSSE and PSCAD Model

IBRs are required to provide active power primary frequency response<sup>14</sup> with a maximum 5% droop for both under<sup>15</sup> and over-frequency events, and a deadband of no greater than  $\pm 36$  mHz. Both the PSSE and PSCAD model must be parametrized such that it is capable of responding to both under and over-frequency events.

### 3.1.5 ASPEN OneLiner IBR Modeling

IBRs are typically modeled as a single aggregate representation for short-circuit studies. In ASPEN OneLiner, the IBR must be represented using the Converter-Interfaced Resource (CIR)<sup>16</sup> model.

Figure 15 below shows the typical data required for the CIR model.

Common deficiencies involve

- inaccurate specification of the generator's MVA capability

<sup>14</sup> [https://www.iso-ne.com/static-assets/documents/rules\\_proceeds/operating/isone/op14/op14\\_rto\\_final.pdf](https://www.iso-ne.com/static-assets/documents/rules_proceeds/operating/isone/op14/op14_rto_final.pdf)

<sup>15</sup> Provided sufficient headroom is available

<sup>16</sup> Refer to Appendix K and Appendix L of the ASPEN OneLiner version 15.9 documentation for additional guidance

- non-zero active power value
- inaccurate maximum positive sequence current injection value and slope
- inaccurate resource shutdown voltages

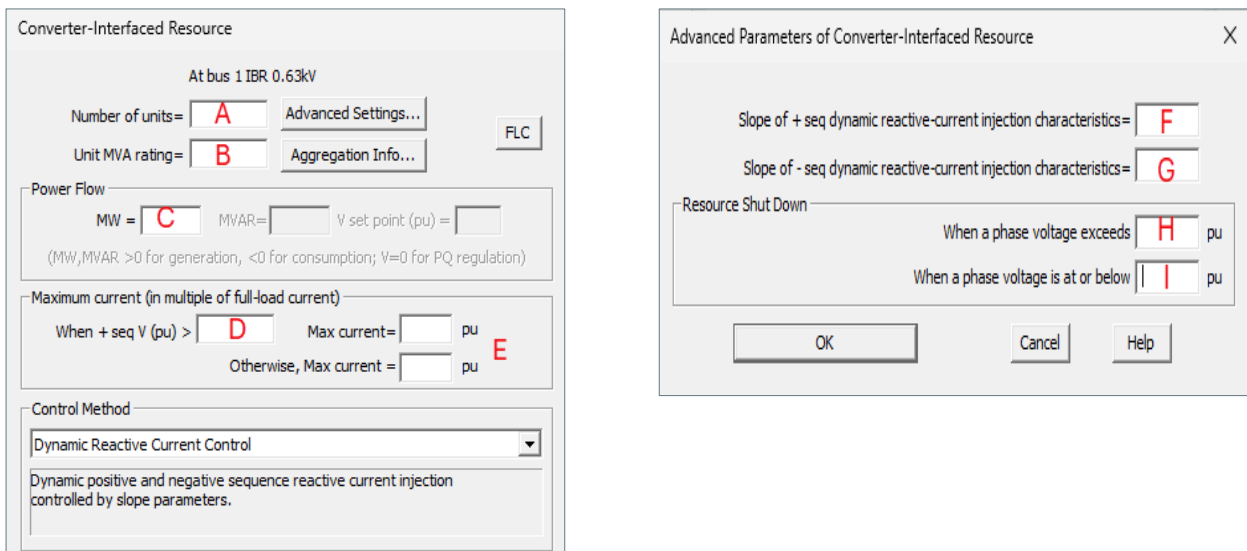

**Figure 15 Converter-Interfaced Resources**

- A – Provide the total number of inverters for the project
- B – Provide the MVA rating of a single inverter
- C – Set this value to zero
- D – F - Data as provided by OEM<sup>17</sup>
- G – This value is typically zero unless inverter will inject negative sequence current
- H - I – Data as provided by OEM

### 3.1.6 PSCAD Model Components

The common deficiencies identified in PSCAD models include the following:

- Implementation of a generic PPC model instead of manufacturer-specific (OEM) model
- Absence of communication delays and sample and hold delays
- Use of generic frequency/phase RMS meter components rather than project-specific configuration or smoothed PSCAD master library FFT
- Time step setting less than 10  $\mu$ s
- The model is only able to run at a specific time step
- Inadequate trip signal modeling and insufficient signal descriptions
- Usage of global variables

<sup>17</sup> The value of the parameter should come from the OEM, parametrized to the extent possible to match the proposed equipment

## Section 4

# Modeling Data Alignment

The interconnection study process relies on several modeling tools that must utilize consistent data inputs to perform accurate analysis. Data misalignment between study models can lead to conflicting outcomes and unexpected delays. This section provides guidance on ensuring proper data alignment and identifies key parameters that require consistency across all modeling tools.

### 4.1 Data Alignment in Simulation Tools

ISO-NE will primarily use three software applications to conduct cluster studies:

- PSSE for steady-state and dynamic analysis
- ASPEN OneLiner (ASPEN) for short-circuit studies
- PSCAD for electromagnetic transient (EMT) studies

#### 4.1.1 Steady State Data Alignment Guidelines

The table below identifies the key generating plant elements that should align across all respective software applications. All modeling data should also align with the IR, Attachments A and A-1, as applicable.

**Table 1 Steady State Data Alignment Guidelines**

| Generating Plant Element      | Parameter                        | Alignment Guidelines  |
|-------------------------------|----------------------------------|---|
| Inverter                      | Power flow data                  | All models (PSSE, PSCAD and ASPEN <sup>18</sup> ) should contain identical values |
|                               | Voltage schedule and control bus | PSSE and PSCAD models should contain identical values                             |
| Generator Step-up Transformer | Positive Sequence Impedance      | All models (PSSE, PSCAD and ASPEN) should contain identical values                |
|                               | Zero Sequence Impedance          | ASPEN model should contain values identical to Attachment A-1                     |
|                               | Winding configuration            | All models (PSSE, PSCAD and ASPEN) should be identical                            |
| Collector system data         | Positive Sequence Impedance      | All models (PSSE, PSCAD and ASPEN) should contain identical values                |

<sup>18</sup> Refer to section 3.1.5 for guidance on IBR modeling in ASPEN OneLiner

|  |                             |  |
|--|-----------------------------|--|
|  | Zero Sequence Impedance     | PSCAD and ASPEN model should contain identical values                                |
| <b>Plant-level Reactive Compensation (If applicable)</b> | Power flow                  | For static compensation device, PSCAD and PSSE model should contain identical values |
|  |                             | For dynamic reactive device, all models (PSSE, PSCAD and ASPEN) should align         |
| <b>Main Power/Station Transformer</b>                    | Positive Sequence Impedance | All models (PSSE, PSCAD and ASPEN) should contain identical values                   |
|  | Zero Sequence Impedance     | ASPEN model should contain values identical to Attachment A-1                        |
|  | Winding configuration       | All models (PSSE, PSCAD and ASPEN) should be identical                               |
| <b>Generator tie line</b>                                | Positive Sequence Impedance | All models (PSSE, PSCAD and ASPEN) should contain identical values                   |
|  | Zero Sequence Impedance     | PSCAD and ASPEN model should contain identical values                                |

#### 4.1.2 Dynamic Data Alignment Guidelines

The table below identifies key dynamic model components that should align across all respective software applications.

**Table 2 Dynamic Data Alignment Guidelines**

| Dynamic Model Component                      | Alignment Guidelines                                       |
|--|--|
| Control flags                                | PSSE and PSCAD should match                                |
| P/Q priority flag                            | PSSE and PSCAD should match                                |
| Voltage Regulation bus/ Point of Measurement | PSSE and PSCAD should match                                |
| Frequency control deadband and droop         | PSSE and PSCAD should match                                |
| Voltage droop (if applicable)                | Effective <sup>19</sup> PSSE and PSCAD values should match |

<sup>19</sup> Due to different modeling platforms, the exact value between the models may be different. However, the droop observed should be the same

